



CEILING & WALL | SYSTEMS

Between us, ideas become reality™

SOUNDSCAPES® Shapes
Acoustical Clouds and Walls



SOUNDSCAPES® Shapes

Acoustical Clouds and Walls



SoundScapes Shapes Circle panels in Pale Lemon

Key Selection Attributes

- Enhance acoustics in open areas
- Aesthetically define spaces
- NEW** • Ten standard flat panels in multiple sizes and shapes, including 2 new shapes; Custom shapes available
- NEW** • Fourteen standard colors; Custom colors available
- Install individually or in groups to create your own unique design
- Full line of hanging kits and accessories
- Adjustable to various heights and angles
- NEW** • Quick and easy to install from a deck, through a ceiling, directly attached to drywall, on a standard suspension system or on a wall
- Engineered and tested for use in seismic areas
- NEW** • For more information about Custom shapes and colors, contact Architectural Specialties at 1 877 ARMSTRONG, select options 1-1-4

Typical Applications

- Exposed structure areas
- Healthcare
- Office
- Education
- Hospitality and retail
- Transportation

Color Selection

Due to printing limitations, shades may vary from actual product.



NOTE: Special care in installation and handling must be taken with color shapes to avoid surface damage to the paint finish. Custom colors are available. Contact Architectural Specialties with a Sherwin-Williams 4-digit color code from the Durations or Harmony flat interior paint families (Code SW _ _ _ _)

Panel Selection

Shown in finish view from below ceiling

Nominal 4' x 4' Shapes

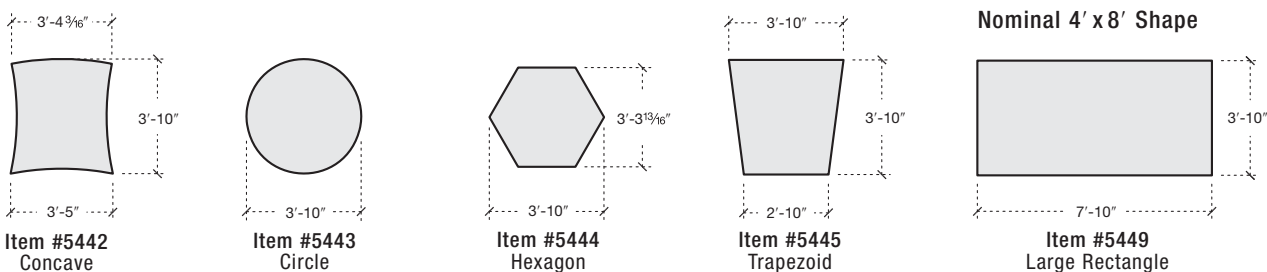
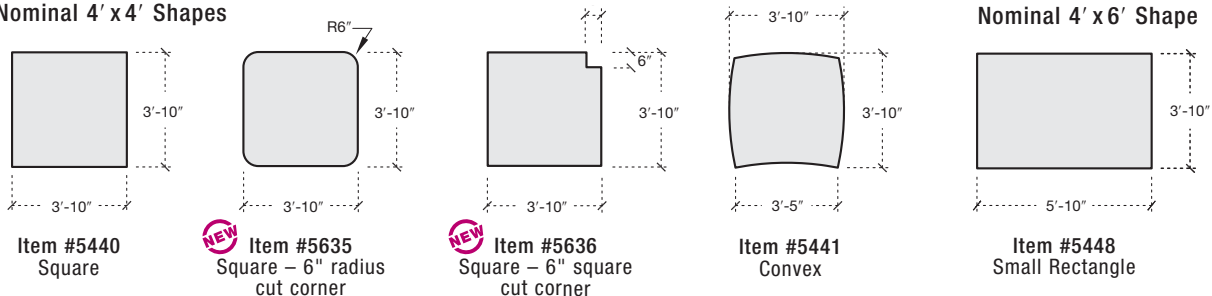



Custom Panel Selection Shown in finish view from below ceiling

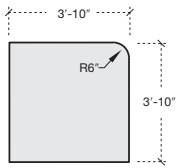

Item #5637

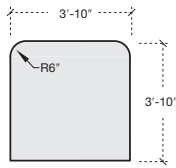

Item #5638

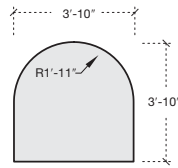

Item #5639

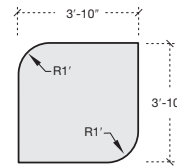

Item #5640

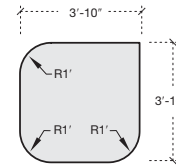

Item #5641

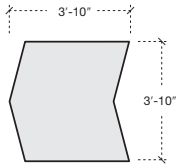

Item #5690

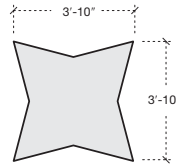

Item #5691

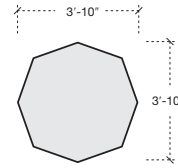

Item #5692

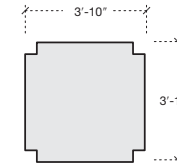

Item #5693

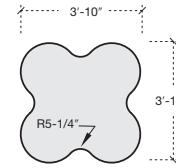

Item #5694

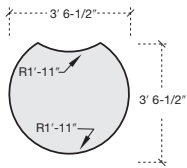

Item #5695

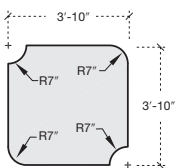

Item #5696

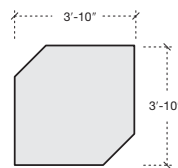

Item #5697

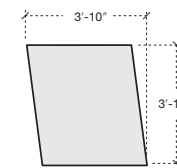

Item #5446

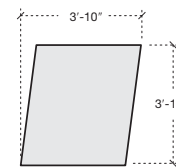

Item #5447



Custom Shapes

Now, you can create your own shapes!

Simply carve your creation out of the allowable custom panel area (interior edge to perimeter edge) as instructed below and send a CAD file to Architectural Specialties at 1 877 ARMSTRONG and select options 1-1-4. The drawings below are also available online at armstrong.com/shapes.

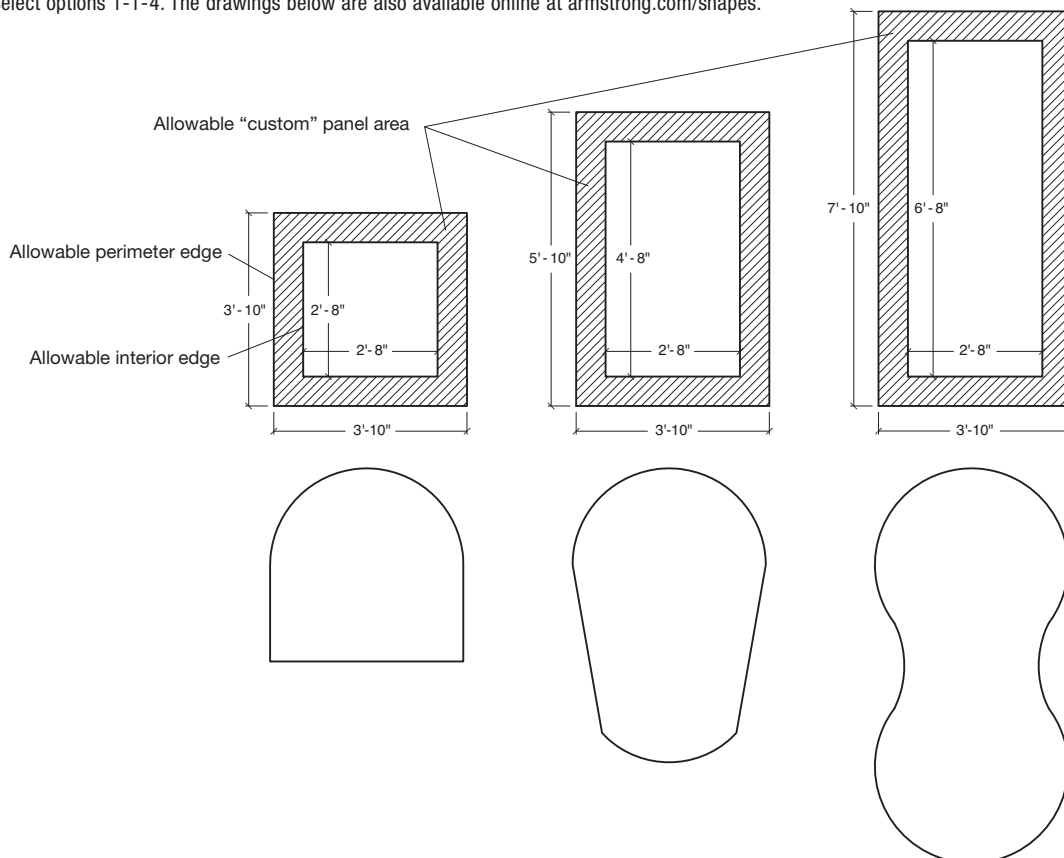

Ways You Can Suspend SoundScapes® Shapes in Groups

Standard Grouping Ideas To create standard groups with a minimum of 2" spacing between shapes, order the kits listed below each group.

4-Panel Square Group Layouts

(4) shapes: (4) 5441 (4) 5442 (4) 5440 (4) 5443 (4) 5444 (4) 5445 (4) 5636 (4) 5636
 + (2) 5450 Deck Hanging Kits (1) 5451 Grouping Frames Kit (1) 5453 Frame Alignment Kit (4) 5454 Panel Hook Kits

4-Panel Linear Group Layouts

(4) shapes: (2) 5441 (4) 5441 (4) 5442 (4) 5440 (4) 5443 (4) 5444 (4) 5445 (4) 5635
 + (4) 5450 Deck Hanging Kits (1) 5451 Grouping Frames Kits (1) 5452 Frame Splice Kit (2) 5453 Frame Alignment Kits
 (4) 5454 Panel Hook Kits

9-Panel Square Group Layouts

(9) shapes: (5) 5441 (9) 5440 (9) 5443 (5) 5440 (9) 5444 (9) 5445 (9) 5635 (4) 5636 (4) 5442 (4) 5443 (5) 5440
 + (5) 5450 Deck Hanging Kits (2) 5451 Grouping Frames Kits (3) 5453 Frame Alignment Kits (9) 5454 Panel Hook Kits

4-Panel Rectangular Layout

(4) shapes: (2) 5440 & (2) 5448
 + (3) 5450 Deck Hanging Kits (1) 5453 Frame Alignment Kit
 (1) 5451 Grouping Frames Kit (4) 5454 Panel Hook Kits

7-Panel Group Layouts

(7) shapes: (7) 5444 or (7) 5443
 + (5) 5450 Deck Hanging Kits (3) 5453 Frame Alignment Kits
 (2) 5451 Grouping Frames Kits (7) 5454 Panel Hook Kits

Custom Grouping Ideas

4-Panel Square Group Layouts

(4) 5637 (4) 5640 (4) 5691 (4) 5692 (4) 5693 (4) 5694 (4) 5696
 + (2) 5450 Deck Hanging Kits (1) 5451 Grouping Frames Kit (1) 5453 Frame Alignment Kit (4) 5454 Panel Hook Kits

4-Panel Linear Group Layouts

(4) 5638 (4) 5639 (4) 5690 (4) 5693 (4) 5695 (4) 5697
 + (4) 5450 Deck Hanging Kits (1) 5451 Grouping Frames Kits
 (1) 5452 Frame Splice Kit (2) 5453 Frame Alignment Kits
 (4) 5454 Panel Hook Kits

9-Panel Square Group Layouts

(9) 5690 (9) 5691 (9) 5697
 + (5) 5450 Deck Hanging Kits (2) 5451 Grouping Frames Kits
 (3) 5453 Frame Alignment Kits (9) 5454 Panel Hook Kits

NOTE: For more information on group configurations and spacing options, visit armstrong.com/shapes or see installation instructions LA-297302. CAD details showing various spacing options depending on panel shape are also available on the web. If you need assistance identifying what and how many accessory kits are needed for your project, please contact TechLine at 1 877 ARMSTRONG and select options 1-1-4.

Acoustical Performance

Sound Absorption in Sabin

The Sabin is the unit of total sound absorption provided by an object. This is the preferred metric for “space absorbers” such as clouds, canopies or baffles installed within an architectural space.

Total acoustical absorption for a suspended ceiling is calculated by multiplying the exposed surface area by the material NRC while “space absorbers” are directly measured. SoundScapes Shapes Acoustical Clouds provide greater sound absorption than a continuous ceiling of the same surface area because the sound is absorbed from both the front and back surfaces.

The installation of clouds in a reverberant space can significantly reduce the background noise and reverberation time, enhancing speech intelligibility.

Factors that may affect the installed acoustical performance relative to the published results are:

- Size and shape of cloud
- Number of clouds and their layout
- Suspension distance below exposed deck or finished ceiling
- Location and vertical or horizontal layering of clouds
- Material selection (fiberglass clouds or mineral fiber canopies)



SoundScapes® Shapes Convex and Concave panels in White

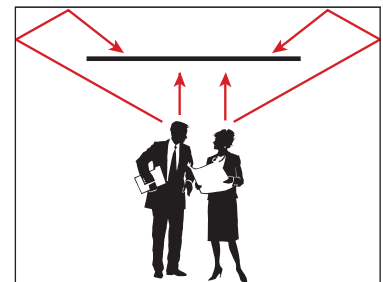

EXPOSED STRUCTURE

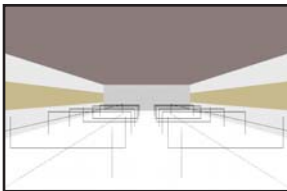

SOUNDSCAPES SHAPES

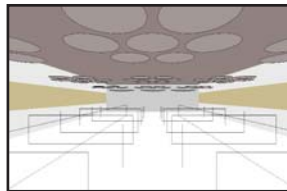

FULL ULTIMA® CEILING

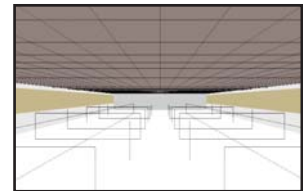

5,000 SF Exposed Structure (50' x 100'), 15' to deck, drywall with windows on two sides, commercial carpet

Ceiling	No Ceiling Exposed Structure	SoundScapes (25% of ceiling)		SoundScapes (50% of ceiling)		Full Ultima Ceiling
		52 SoundScapes Canopies*	105 SoundScapes Shapes-Circles	100 SoundScapes Canopies*	217 SoundScapes Shapes-Circles	
Reverberation Time (RT)	3.4s	1.6s	1.4s	1.0s	0.9s	0.5s
RT Improvement	ref	+53%	+58%	+70%	+74%	+85%
Background Noise Reduction	ref	-1.6 dB	-2.0 dB	-2.6 dB	-3.0 dB	-5.0 dB
Total Sabin for Coverage Area	none	1248 sf x 1.25 = 1560	1216 sf x 1.49 = 1812	2400 sf x 1.25 = 3000	2515 sf x 1.49 = 3747	5000 sf x 0.70 = 3500

* For product information on SoundScapes Acoustical Canopies, see CS-3691 or visit armstrong.com/soundsapes. You can calculate the acoustical difference that SoundScapes make in your space by using our online Reverb Calculator Tool at armstrong.com/reverbtool

NOTE: Results based on acoustical testing of White SoundScapes Shapes Circle panels suspended 48" below the deck. The absorption is approximately 10% lower for color panels and 20% lower for direct attachment to drywall.

Installation Options

1. Individual Suspension

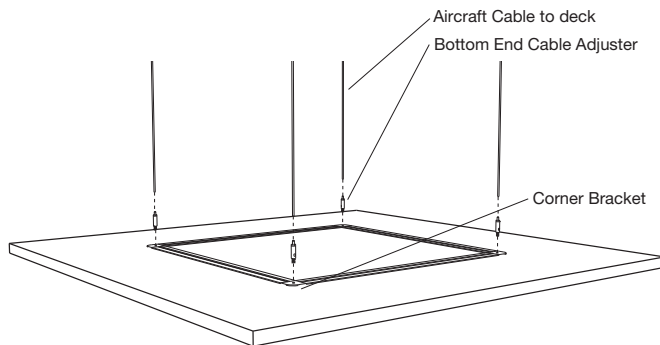

With individual suspension to the deck, you need the following for each type of shape:

Nominal 4' x 4' and 4' x 6' Shapes	Nominal 4' x 8' Shape
(1) Shape (Items 5440 through 5448 and 5635, 5636)	(1) Item 5449, Large Rectangle
(2) 5450 Deck Hanging Kits	(3) 5450 Deck Hanging Kits

2. Individual Attachment to Drywall (or a solid surface)

Ceiling Application

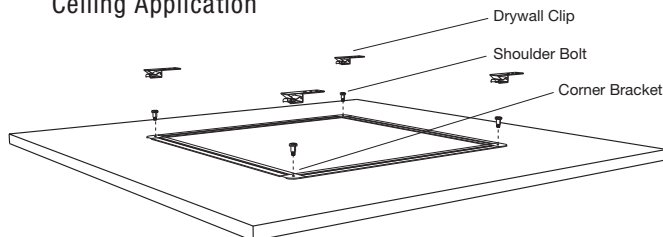

Wall Application

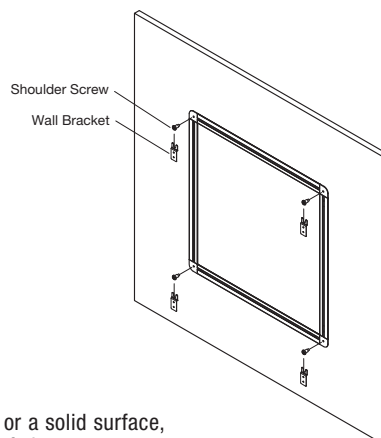

With individual attachment to drywall or a solid surface, you need the following for each type of shape:

Nominal 4' x 4' and 4' x 6' Shapes	Nominal 4' x 4' and 4' x 6' Shapes
(1) Shape (Items 5440 through 5448 and 5635, 5636)	(1) Item 5449, Large Rectangle
(2) 5455 Drywall Hanging Kits for a ceiling installation, or 5588 for a wall	(3) 5455 Drywall Hanging Kits for a ceiling installation, or 5588 for a wall

NOTE: See installation instructions LA-297302 for details. If you need assistance identifying what and how many accessory kits are needed for your project, please contact TechLine at 1 877 ARMSTRONG.

Installation View



(3) 5443 in White

Installation View

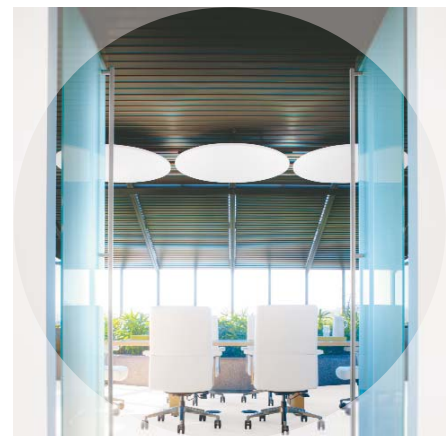

(3) 5443 in White

Installation Options

3. Group Suspension

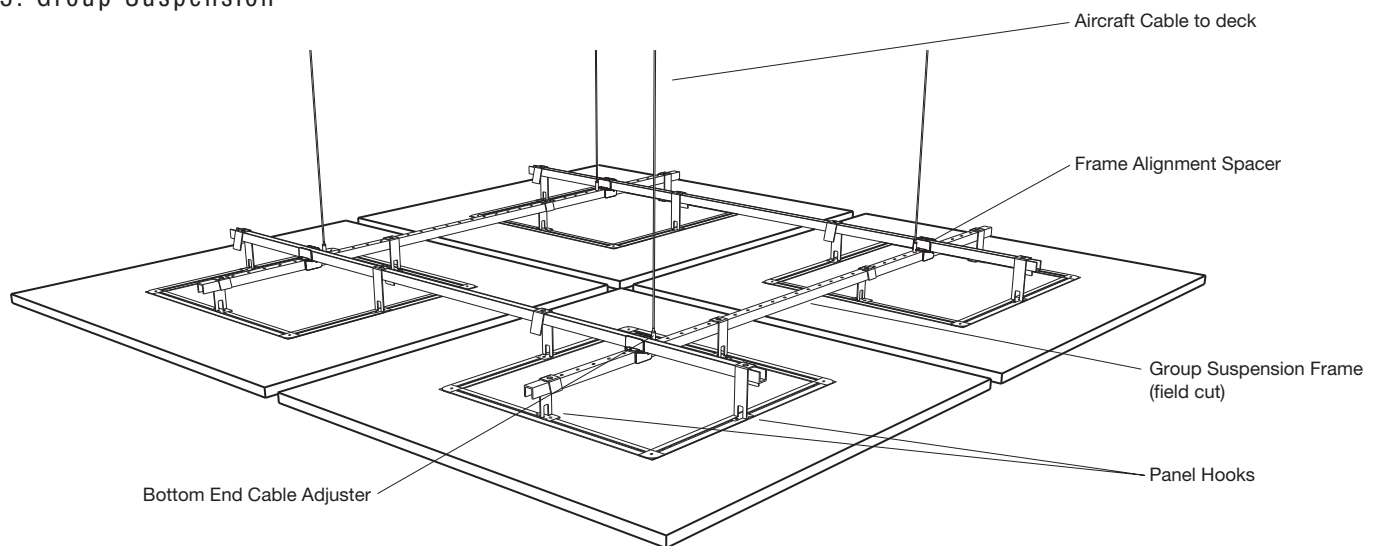

SoundScapes® Shapes can also be installed together using a variety of group-related accessory kits. Group assemblies have been engineered for use in all seismic areas.

As an example, to install the design layout above with a minimum of 2" spacing between shapes, you would need to order:

Nominal 4' x 4' Shapes
(4) Shapes (items 5440 through 5447 and 5635, 5636)
(2) 5450 – Deck Hanging Kits
(1) 5451 – Grouping Frames Kit
(1) 5453 – Frame Alignment Kit
(4) 5454 – Panel Hook Kits

Installation Views



5441 and 5442 in White
(1) 9 panel square group layout



5441 and 5442 in White and Moss
(3) 9 panel square group layouts

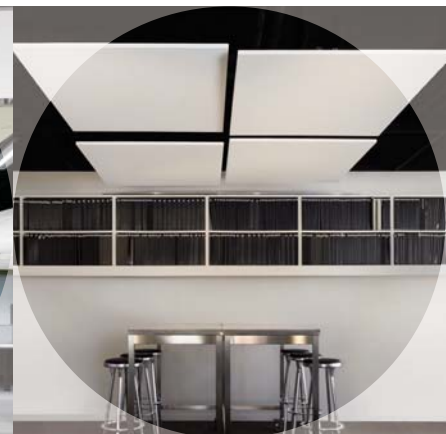

(4) 5440 in White
(1) 4 panel square group layout with multi-plane hanging kit

NOTE: See installation instructions LA-297302 for details on typical group configurations. CAD details are also available on the web at armstrong.com/shapes. Installation will require field cutting of the grouping frames. Please note: Increasing the spacing between shapes may require additional hardware. If you need assistance identifying what and how many accessory kits are needed for your project, please contact TechLine at 1 877 ARMSTRONG.



Before: Acoustic tile

After: SoundScapes® Custom Shapes and Canopies in Custom colors

Case Study

Project: Carmen & David's Creamery

Location: Lancaster, PA

Product: SoundScapes Custom Acoustical Shapes and Canopies

Challenge: Before they opened their new establishment, the owners of Carmen & David's Creamery transformed a former coffee shop with dark purple and deep red interior into a whimsical ice cream parlor with bright, cheerful sherbet colors.

As co-owner Carmen Garcia-Hommel explained, "We were able to add color to just about every surface in the shop but the ceiling "because we thought we couldn't do anything with it, she said."

Solution: To complete the transformation, co-owner David Hommel partnered with Armstrong Ceilings to install a variety of new SoundScapes Custom Shapes and Canopies throughout the shop.

A three-part custom ceiling cloud in the shape of a cone with two scoops of ice cream now highlights the ceiling in the serving area, while a pair of cones, each with a single scoop, adorn the adjacent seating area. In addition, seven convex and concave SoundScapes Canopies were installed. All of the clouds and canopies are in custom colors that coordinate with the sherbet-like colors of the shop's interior.

"The installation of the shapes and canopies has added wonderful depth and visual appeal to the ceiling. Everyone who comes in looks up and can't help but notice them, said Garcia-Hommel."



SOUNDSCAPES® Shapes

Acoustical Clouds and Walls

Recycled Content: **82%**

armstrong.com/greengenie

LEED® Credits

Energy	Waste Mgmt	Recycled Content	Local Materials	Renewable Materials	Daylight & Views
✓	✓	✓	✓		✓

Location Dependent

LEED for Schools

Acoustics	Low Emitting or CHPS
✓	✓

Colors

White (WH)	Sky (SK)	Lagoon (LA)	Tangerine (TG)
Shell (SH)	Moss (MS)	Plum (PM)	Black (BK)
Pale Lemon (LM)	Stone (SE)	Cranberry (CN)	
Pecan (PC)	Reef (RE)	Kiwi (KW)	

Visual Selection

Suspension Options

Item Number*	Description	Dimensions*
SOUNDSCAPES Shapes		
5440__	Square	Nominal 4' x 4' x 7/8"
5441__	Convex	Nominal 4' x 4' x 7/8"
5442__	Concave	Nominal 4' x 4' x 7/8"
5443__	Circle	Nominal 4' x 4' x 7/8"
5444__	Hexagon	Nominal 4' x 4' x 7/8"
5445__	Trapezoid	Nominal 4' x 4' x 7/8"
NEW 5635__	Square – 6" radius cut corner	Nominal 4' x 4' x 7/8"
NEW 5636__	Square – 6" square cut corner	Nominal 4' x 4' x 7/8"
5448__	Small Rectangle	Nominal 4' x 6' x 7/8"
5449__	Large Rectangle	Nominal 4' x 8' x 7/8"

- * Add 2-letter color suffix to item number when specifying or ordering. (Ex: 5440WH for square panel in White)
- * Exact dimensions for each shape are shown on page 1 inside.

1. Individual Suspension (See page 5 inside)

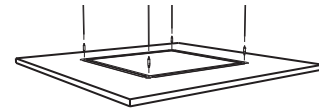

2. Individual Attachment to Drywall (or a solid surface) (See page 5 inside)

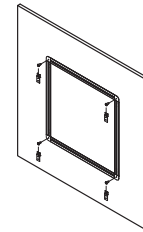
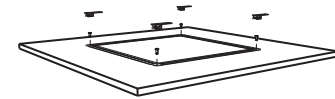

3. Group Suspension (See page 6 inside)

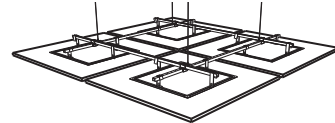

Physical Data

Material

7/8" thick Fiberglass with DuraBrite® scrim on face and sides

Surface Finish

DuraBrite with factory-applied paint on face and sides. Standard White has energy-saving, high light-reflective finish (LR 0.90). Back of panel is unfinished with embedded metal extrusions.

Panel Weight

0.63 lbs/SF

Design Considerations

SoundScapes Shapes maintain a natural sag that may not be noticeable when installed 6" or less apart. Deflection up to 1/8" has been documented in some cases.

Special care in installation and handling must be taken with color shapes to avoid surface damage to the paint finish. Custom colors are available. Contact Architectural Specialties with a Sherwin-Williams color code from the Durations or Harmony flat interior paint families (Code SW _ _ _ _)

Custom shapes are available by providing a custom shape drawing within guidelines for creating a custom shape on page 2 to Architectural Specialties at 1 877 ARMSTRONG, and select options 1-1-4.

Fire Performance

SoundScapes Shapes panel material is ASTM E84 Class A: Flame Spread 25 or under and Smoke Developed 50 or less.

SoundScapes Shapes, as with other architectural features located in the ceiling plane, may obstruct or skew the existing or planned fire sprinkler water distribution pattern, or possibly delay the activation of the fire sprinkler or fire detection system. Consult a fire protection engineer, NFPA 13, and local codes for guidance on the proper installation techniques where fire detection or suppression systems are present.

ASTM E1264 Classification

Type XII, Form 2, Pattern E

Acoustical Performance

SoundScapes Shapes offer excellent sound absorption. They provide greater sound absorption than a continuous ceiling of the same area because sound is absorbed from front and back surfaces. Color shapes have slightly reduced acoustical performance. See data page CS-3867 for details.

Seismic Restraint*

The International Building Code allows architectural components to swing freely as long as they will not be damaged or cause damage. Shapes suspended individually with aircraft cable will swing no more than 18" in any direction for each panel. Shapes directly attached to drywall or suspended in group systems have been engineered for application in all seismic areas.

* Pendulum reaction information is based on full-scale testing and computer modeling conducted at the Structural Engineering Earthquake Simulation Lab located at the State University of New York at Buffalo.

Recommended Suspension Systems

SoundScapes Shapes are pre-assembled with metal extrusions in the back of the panels. Standard accessory kits facilitate quick and easy installation from the deck, through a ceiling or directly attached to drywall. See Installation Instructions LA-297302 for installation details.

Warranty

One (1) year limited warranty. Details: armstrong.com/warranty.

Accessory Kits – Applications always require more than one kit.

ITEM # KIT CONTENTS

5450 – Deck Hanging Kit

Allows for suspending individual shapes or grouping frames from deck and bottom end adjustment of height at panel or frame level.

- (2) gripper structure anchors
- (2) gripper structure caps
- (2) 8' aircraft cables
- (2) bottom end cable adjusters
- (2) nuts with washers



NEW

5438 – Angled Hanging Kit

For use when hanging panels at different angles. Extends from the end of Deck Hanging Kit (5450).

- (2) angled hanging cables



625530 – Extended Hanging Cables

For use with deck hanging kit when longer cables are needed

- (4) 30' aircraft cables

7006 – Escutcheon Kit

Used when hanging panels below an existing ceiling

- (2) collars with set screws
- (2) 2" escutcheons



5451 – Grouping Frames Kit

Suspension frames used to group panels together

- (4) suspension frames, 12' long, black

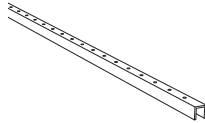

5452 – Frame Splice Kit

Connects group suspension frames for longer runs (> 12 feet)

- (2) group frame connectors, 10" long, black
- (4) bolts with washers
- (4) nuts

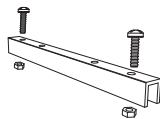

5453 – Frame Alignment Kit

For use with group suspension frames

- (4) frame alignment spacers, clear plastic
- (4) bolts
- (4) nuts with washers

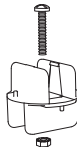

ITEM # KIT CONTENTS

5454 – Panel Hook Kit

For use with group frames, (one kit per all panels except item 5449, Large Rectangle, which requires 2 kits)

- (2) 4-1/2" high panel hooks, black
- (2) 3-1/2" high panel hooks, black
- (8) bolts

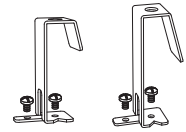

NEW

Multi-plane Hanging Kits

For use when hanging panels at heights below Panel Hook Kit (5454).

5629 – 1" Drop Hook Kit

- (2) 4-1/2" hooks
- (2) 5-1/2" hooks
- (8) screws

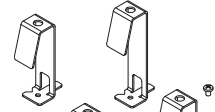

5630 – 2" Drop Hook Kit

- (2) 5-1/2" hooks
- (2) 6-1/2" hooks
- (8) screws

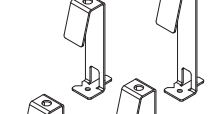

5631 – 3" Drop Hook Kit

- (2) 6-1/2" hooks
- (2) 7-1/2" hooks
- (8) screws

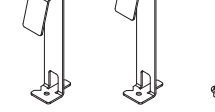

5455 – Drywall Ceiling Hanging Kit

For individual panel attachment to drywall

- (2) drywall clip assemblies
- (2) shoulder bolts

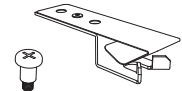

NEW

5588 – Wall Hanging Kit

For individual panel attachment to a wall.

- (4) clip assemblies
- (4) shoulder bolts

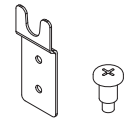

NEW

5632 – Grid Hook Kit

For hanging individual panels from a standard suspension system.

- (4) hooks
- (8) screws

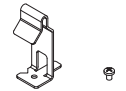

NOTE: If you need assistance identifying what and how many accessory kits are needed for your project, please contact TechLine at 1 877 ARMSTRONG.

Accessory kit hardware is attached to panels via the metal extrusion or corner brackets on the back of each panel. This diagram shows the location of extrusions and corner brackets in the back of each size panel. See installation instructions LA-297302 for more details.

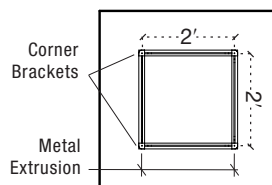

Nominal 4' x 4' Shapes